



Control relay, 24 V DC, 12DI(4AI), 6DO relays, 1AO, time, expandable, easyNet

Part no. EASY820-DC-RCX
Article no. 256272

Delivery program

| | | | |
|--------------------------------|--|--------|--|
| Product range | | | Control relays easyRelay |
| Basic function | | | easy800 (expandable, easyNet) |
| Description | | | Expandable: Digital/analog inputs/outputs and AS-Interface, PROFIBUS-DP, CANopen®, DeviceNet bus systems Bus system easyNet on board customized laser inscription or delivery with user program possible with EASY-COMBINATION-* product (article No. 2010781) |
| Inputs | | | |
| Digital input count | | | digital: 12 digital: 12; of which can be used as analog: 4 |
| Digital | | | 12 |
| of which can be used as analog | | | 4 |
| Outputs | | | |
| Type | | | Relay Analog |
| Quantity of outputs | | | Relays: 6 Relays: 6; analog: 1 |
| Outputs | | Number | 7 |
| Relay 10 A (UL) | | | 6 |
| Analog | | | 1 |
| Additional features | | | |
| Display | | | without display, without keypad |
| Real time clock | | | ✓ |
| Expansions | | | Expandable Networkable (easyNet) |
| Supply voltage | | | 24 V DC |
| Software | | | EASY-SOFT-PRO |

Technical data

General

| | | | |
|------------------------|--|----|--|
| Standards | | | EN 55011, EN 55022, IEC/EN 61000-4, IEC 60068-2-6, IEC 60068-2-27 |
| Dimensions (W x H x D) | | mm | 107.5 x 90 x 72 (6 PE) |
| Weight | | kg | 0.3 |
| Mounting | | | Top-hat rail IEC/EN 60715, 35 mm or screw fixing using fixing brackets ZB4-101-GF1 (accessories) |

Terminal capacities

| | | | |
|------------------------|--|-----------------|-----------------------|
| Solid | | mm ² | 0.2/4 (AWG 22 - 12) |
| Flexible with ferrule | | mm ² | 0.2/2.5 (AWG 22 - 12) |
| Standard screwdriver | | mm | 3.5 x 0.8 |
| Max. tightening torque | | Nm | 0.6 |

Climatic environmental conditions

| | | | |
|-------------------------------|---|-----|---|
| Operating ambient temperature | | °C | In accordance with IEC 60068-2-1, -25 - +55 |
| Condensation | | | Take appropriate measures to prevent condensation |
| Storage | 9 | °C | In accordance with IEC 60068-2-1, -2, -14 -40 - +70 |
| relative humidity | | % | in accordance with IEC 60068-2-30, IEC 60068-2-78 5 - 95 |
| Air pressure (operation) | | hPa | 795 - 1080 |

Ambient conditions, mechanical

| | | | |
|--|--------------|----|--|
| Protection type (IEC/EN 60529, EN50178, VBG 4) | | | IP20 |
| Vibrations | 3,5 mm / 1 g | Hz | In accordance with IEC 60068-2-6 constant amplitude 0.15 mm: 10 - 57 constant acceleration 2 g: 57 - 150 |

| | | | |
|--|-------------|---------|------------------------|
| Mechanical shock resistance (IEC/EN 60068-2-27) semi-sinusoidal 15 g/11 ms | | Impacts | 18 |
| Drop to IEC/EN 60068-2-31 | Drop height | mm | 50 |
| Free fall, packaged (IEC/EN 60068-2-32) | | m | 1 |
| Mounting position | | | Vertical or horizontal |

Electromagnetic compatibility (EMC)

| | | | |
|---|--|-----|--|
| Overvoltage category/pollution degree | | | III/2 |
| Electrostatic discharge (ESD) | | | |
| applied standard | | | according to IEC EN 61000-4-2 |
| Air discharge | | kV | 8 |
| Contact discharge | | kV | 6 |
| Electromagnetic fields (RFI) to IEC EN 61000-4-3 | | V/m | 0.8 - 1.0 GHz: 10 1.4 - 2 GHz: 3 2.0 - 2.7 GHz: 1 |
| Radio interference suppression | | | EN 55011 Class B |
| Burst | | kV | according to IEC/EN 61000-4-4 |
| power pulses (Surge) | | | according to IEC/EN 61000-4-5 1 kV (supply cables, symmetrical) |
| Immunity to line-conducted interference to (IEC/EN 61000-4-6) | | V | 10 |

Insulation resistance

| | | | |
|---|--|--|--------------------------------------|
| Clearance in air and creepage distances | | | EN 50178, UL 508, CSA C22.2, No. 142 |
| Insulation resistance | | | EN 50178 |

Back-up of real-time clock

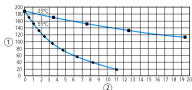
| | | | |
|---------------------------------------|--|-------|--|
| Back-up of real-time clock | | |  <p>① Backup time (hours) with fully charged double layer capacitor ② Service life (years)</p> |
| Accuracy of real-time clock to inputs | | s/day | typ. ± 2 (± 0.2 h/Year) depending on ambient air temperature fluctuations of up to ± 5 s/day (± 0.5 h/year) are possible |

Repetition accuracy of timing relays

| | | | |
|---------------------------------------|--|-----|------------|
| Accuracy of timing relays (of values) | | % | ± 0.02 |
| Resolution | | | |
| Range "S" | | ms | 5 |
| Range "M:S" | | s | 1 |
| Range "H:M" | | min | 1 |

Retentive memory







| | | | |
|--------------------------------------|--|--|-------------------------------|
| Write cycles of the retentive memory | | | 10^{12} (read/write cycles) |
|--------------------------------------|--|--|-------------------------------|

Power supply

| | | | |
|---------------------------|-------|----|--|
| Rated operational voltage | U_e | V | 24 DC (-15/+20%) |
| Permissible range | U_e | | 20.4 - 28.8 V DC |
| Residual ripple | | % | ≤ 5 |
| Siemens MPI, (optional) | | | yes |
| Input current | | | 140 mA at U_e |
| Voltage dips | | ms | \leq In accordance with IEC 61131-2 ≤ 20 |
| Fuse | | A | ≤ 1 A (T) |
| Power loss | P | W | Normally 3.4 |

Digital inputs 24 V DC

| | | | |
|-------------------------------------|-------|------|--|
| Number | | | 12 |
| Inputs can be used as analog inputs | | | 4 (I7, I8, I11, I12) |
| Potential isolation | | | from power supply: no between digital inputs: no from the outputs: yes to interface/memory card: no to easyLink: no to easyNet: yes |
| Rated operational voltage | U_e | V DC | 24 |
| Input voltage | | V DC | Signal 0: ≤ 5 (I1 - I6, I9, I10), ≤ 8 (I7, I8, I11, I12) |



| | | |
|---------------------------|-----|---|
| Input current at signal 1 | mA | Signal 1:  15 (I1 - I6, I9, I10),  8 (I7, I8, I11, I12) |
| Deceleration time | ms | I1 - I6, I9, I10: 3.3 (at 24 V DC) I7, I8, I11, I12: 2.2 (at 24 V DC) |
| Cable length | m | 20 (0 -> 1/1 -> 0, Debounce ON) normally 0.025 (0 -> 1/1 -> 0, Debounce OFF, I1 - I4) normally 0.25 (0 -> 1/1 -> 0, Debounce OFF, I5, I6, I9, I10) normally 0.15 (0 -> 1/1 -> 0, Debounce OFF, I7, I8, I11, I12) |
| Frequency counter | | |
| Number | | 4 (I1, I2, I3, I4) |
| Counter frequency | kHz |  5 |
| Pulse shape | | Square |
| Pulse pause ratio | | 1:1 |
| Cable length | m |  20 (screened) |
| Incremental counter | | |
| Number of counter inputs | | 2 (I1 + I2, I3 + I4) |
| Counter frequency | kHz |  3 |
| Pulse shape | | Square |
| Signal offset | | 90° |
| Pulse pause ratio | | 1:1 |
| Rapid counter inputs | | |
| Number | | 4 (I1, I2, I3, I4) |
| Cable length | m |  20 (screened) |
| Counter frequency | kHz | < 5 |
| Pulse shape | | Square |
| Pulse pause ratio | | 1:1 |

Analog inputs

| | | |
|---------------------------------|----|--|
| Number | | 4 (I7, I8, I11, I12) |
| Potential isolation | | from power supply: no between digital inputs: no from the outputs: yes to interface/memory card: no to easyLink: no to easyNet: yes |
| Input type | | DC voltage |
| Signal range | | 0-10 V DC |
| Resolution | | 0.01 V analog 0.01 V digital 10 Bit (value 0 - 1023) |
| Input impedance | kΩ | 11.2 |
| Accuracy of actual value | | |
| Two EASY devices | % | ± 3 |
| Within a single device | % | ± 2, (I7, I8, I11, I12) ± 0.12 V |
| Conversion time, analog/digital | ms | each CPU cycle |
| Input current | mA | < 1 |
| Cable length | m |  30, screened |

Analog outputs

| | | |
|---------------------------------------|---|---|
| Number | | 1 |
| Potential isolation | | from power supply: no To the digital inputs: no From the digital outputs: yes to interface/memory card: yes to easyNet: yes to easyLink: yes |
| Output type | | DC voltage |
| Signal range | | 0-10 V DC |
| Max. output current | A | 0.01 |
| Load resistance | | 1 kΩ |
| Overload and short-circuit protection | | Yes |
| Resolution | | 0.01 V DC analog |

| | | | |
|---|----------------|-------------------|--|
| | | | 10 Bit (value 0 - 1023) digital |
| Recovery time | | μs | 100 |
| Accuracy | | | |
| -25 °C - 55 °C | | % | 2 |
| 25°C | | % | 1 |
| Conversion time, analog/digital | | ms | each CPU cycle |
| Relay outputs | | | |
| Number | | | 6 |
| Outputs in groups of | | | 1 |
| Parallel switching of outputs for increased output | | | Not permissible |
| Protection of an output relay | | | Miniature circuit-breaker B16 or fuse 8 A (slow) |
| Potential isolation | | | from power supply: yes From the inputs: yes between digital inputs: yes to the interface: yes to easyLink: yes to easyNet: yes Safe isolation according to EN 50178: 300 V AC Basic isolation: 600 V AC |
| Lifespan, mechanical | Operations | x 10 ⁶ | 10 |
| Contacts | | | |
| Conventional thermal current (10 A UL) | | A | 8 |
| Recommended for load: 12 V AC/DC | | mA | > 500 |
| Short-circuit-proof cos φ = 1, characteristic B16 at 600 A | | A | 16 |
| Short-circuit-proof cos φ = 0.5 to 0.7, characteristic B16 at 900 A | | A | 16 |
| Rated impulse withstand voltage U _{imp} of contact coil | | kV | 6 |
| Rated operational voltage | U _e | V AC | 250 |
| Rated insulation voltage | U _i | V AC | 250 |
| Safe isolation according to EN 50178 | | V AC | 300 between coil and contact 300 between two contacts |
| Making capacity | | | |
| AC--15, 250 V AC, 3 A (600 ops./h) | Operations | | 300000 |
| DC-13, L/R  150 ms, 24 V DC, 1 A (500 S/h) | Operations | | 200000 |
| Breaking capacity | | | |
| AC-15, 250 V AC, 3 A (600 Ops./h) | Operations | | 300000 |
| DC-13, L/R  150 ms, 24 V DC, 1 A (500 S/h) | Operations | | 200000 |
| Filament bulb load | | | |
| 1000 W at 230/240 V AC | Operations | | 25000 |
| 500 W at 115/120 V AC | Operations | | 25000 |
| Fluorescent lamp load | | | |
| Fluorescent lamp load 10 x 58 W at 230/240 V AC | | | |
| With upstream electrical device | Operations | | 25000 |
| Uncompensated | Operations | | 25000 |
| Fluorescent lamp load 1 x 58 W at 230/240 V AC, conventional, compensated | Operations | | 25000 |
| Switching frequency | | | |
| Mechanical operations | | x 10 ⁶ | 10 |
| Switching frequency | | Hz | 10 |
| Resistive load/lamp load | | Hz | 2 |
| Inductive load | | Hz | 0.5 |
| UL/CSA | | | |
| Uninterrupted current at 240 V AC | | A | 10 |
| Uninterrupted current at 24 V DC | | A | 8 |
| AC | | | |
| Control Circuit Rating Codes (utilization category) | | | |
| Max. rated operational voltage | | V AC | 300 |
| max. thermal continuous current cos φ = 1 at B 300 | | A | 5 |
| max. make/break cos φ ≠ capacity 1 at B 300 | | VA | 3600/360 |
| DC | | | |

| | | | |
|---|--|------|------------------------|
| Control Circuit Rating Codes (utilization category) | | | R 300 Light Pilot Duty |
| Max. rated operational voltage | | V DC | 300 |
| Max. thermal uninterrupted current at R 300 | | A | 1 |
| Max. make/break capacity at R 300 | | VA | 28/28 |

Supply voltage U_{Aux}

| | | | |
|------------|---|---|-----|
| Power loss | P | W | 3.4 |
|------------|---|---|-----|

Network easyNet

| | | | |
|--|--|--|---|
| Data transfer rate/distance | | | 1000 KBit/s, 6 m 500 KBit/s, 25 m 250 Kbit/s, 40 m 125 Kbit/s, 300 m 50 KBit/s, 300 m 20 KBit/s, 700 m 10 KBit/s, 1000 m Lengths from 40 m can be obtained only with cables with reinforced cross-section and terminal adapter. |
| Potential isolation | | | from power supply POW: yes From the inputs: yes from the outputs: yes to easyLink: yes to the interface: yes |
| Bus termination (first and last station) | | | yes |
| Terminal types | | | RJ45, 8-polig |
| Terminal capacity | | | up to 1000 m, < 16 mΩ/m: 1.5 (AWG: 16) up to 600 m, < 26 mΩ/m: 0.75 - 0.8 (AWG: 18) up to 600 m, < 26 mΩ/m: 0.5 - 0.6 (AWG: 20, 19) up to 400 m, < 40 mΩ/m: 0.34 - 0.5 (AWG: 22, 21, 20) up to 250 m, < 60 mΩ/m: 0.25 - 0.34 (AWG: 23, 22) up to 175 m, < 70 mΩ/m: 0.13 (AWG: 26) up to 40 m, < 140 mΩ/m: 1.5 (AWG: 16) |

Design verification as per IEC/EN 61439

| | | | |
|--|------------|----|--|
| Technical data for design verification | | | |
| Rated operational current for specified heat dissipation | I_n | A | 0 |
| Heat dissipation per pole, current-dependent | P_{vid} | W | 0 |
| Equipment heat dissipation, current-dependent | P_{vid} | W | 0 |
| Static heat dissipation, non-current-dependent | P_{vs} | W | 3.4 |
| Heat dissipation capacity | P_{diss} | W | 0 |
| Operating ambient temperature min. | | °C | -25 |
| Operating ambient temperature max. | | °C | 55 |
| IEC/EN 61439 design verification | | | |
| 10.2 Strength of materials and parts | | | |
| 10.2.2 Corrosion resistance | | | Meets the product standard's requirements. |
| 10.2.3.1 Verification of thermal stability of enclosures | | | |
| 10.2.3.2 Verification of resistance of insulating materials to normal heat | | | Meets the product standard's requirements. |
| 10.2.3.3 Verification of resistance of insulating materials to abnormal heat and fire due to internal electric effects | | | Meets the product standard's requirements. |
| 10.2.4 Resistance to ultra-violet (UV) radiation | | | Meets the product standard's requirements. |
| 10.2.5 Lifting | | | Does not apply, since the entire switchgear needs to be evaluated. |
| 10.2.6 Mechanical impact | | | Does not apply, since the entire switchgear needs to be evaluated. |
| 10.2.7 Inscriptions | | | Meets the product standard's requirements. |
| 10.3 Degree of protection of ASSEMBLIES | | | Meets the product standard's requirements. |
| 10.4 Clearances and creepage distances | | | Meets the product standard's requirements. |
| 10.5 Protection against electric shock | | | Does not apply, since the entire switchgear needs to be evaluated. |
| 10.6 Incorporation of switching devices and components | | | Does not apply, since the entire switchgear needs to be evaluated. |
| 10.7 Internal electrical circuits and connections | | | Is the panel builder's responsibility. |
| 10.8 Connections for external conductors | | | Is the panel builder's responsibility. |
| 10.9 Insulation properties | | | |
| 10.9.2 Power-frequency electric strength | | | Is the panel builder's responsibility. |
| 10.9.3 Impulse withstand voltage | | | Is the panel builder's responsibility. |
| 10.9.4 Testing of enclosures made of insulating material | | | Is the panel builder's responsibility. |
| 10.10 Temperature rise | | | The panel builder is responsible for the temperature rise calculation. Eaton will provide heat dissipation data for the devices. |

| | | |
|-------------------------------------|--|--|
| 10.11 Short-circuit rating | | Is the panel builder's responsibility. |
| 10.12 Electromagnetic compatibility | | Is the panel builder's responsibility. |
| 10.13 Mechanical function | | The device meets the requirements, provided the information in the instruction leaflet (IL) is observed. |

Technical data ETIM 6.0

PLC's (EG000024) / Logic module (EC001417)

Electric engineering, automation, process control engineering / Control / Programmable logic control (SPS) / Logic module (ecl@ss8.1-27-24-22-16 [AKE539011])

| | | |
|---|---|-------------|
| Supply voltage AC 50 Hz | V | 0 - 0 |
| Supply voltage AC 60 Hz | V | 0 - 0 |
| Supply voltage DC | V | 20.4 - 28.8 |
| Voltage type of supply voltage | | DC |
| Switching current | A | 8 |
| Number of analogue inputs | | 4 |
| Number of analogue outputs | | 1 |
| Number of digital inputs | | 12 |
| Number of digital outputs | | 6 |
| With relay output | | Yes |
| Number of HW-interfaces industrial Ethernet | | 0 |
| Number of HW-interfaces PROFINET | | 0 |
| Number of HW-interfaces RS-232 | | 0 |
| Number of HW-interfaces RS-422 | | 0 |
| Number of HW-interfaces RS-485 | | 0 |
| Number of HW-interfaces serial TTY | | 0 |
| Number of HW-interfaces USB | | 0 |
| Number of HW-interfaces parallel | | 0 |
| Number of HW-interfaces Wireless | | 0 |
| Number of HW-interfaces other | | 3 |
| With optical interface | | No |
| Supporting protocol for TCP/IP | | No |
| Supporting protocol for PROFIBUS | | No |
| Supporting protocol for CAN | | No |
| Supporting protocol for INTERBUS | | No |
| Supporting protocol for ASI | | No |
| Supporting protocol for KNX | | No |
| Supporting protocol for MODBUS | | No |
| Supporting protocol for Data-Highway | | No |
| Supporting protocol for DeviceNet | | No |
| Supporting protocol for SUCONET | | No |
| Supporting protocol for LON | | No |
| Supporting protocol for PROFINET IO | | No |
| Supporting protocol for PROFINET CBA | | No |
| Supporting protocol for SERCOS | | No |
| Supporting protocol for Foundation Fieldbus | | No |
| Supporting protocol for EtherNet/IP | | No |
| Supporting protocol for AS-Interface Safety at Work | | No |
| Supporting protocol for DeviceNet Safety | | No |
| Supporting protocol for INTERBUS-Safety | | No |
| Supporting protocol for PROFIsafe | | No |
| Supporting protocol for SafetyBUS p | | No |
| Supporting protocol for other bus systems | | Yes |
| Radio standard Bluetooth | | No |
| Radio standard WLAN 802.11 | | No |
| Radio standard GPRS | | No |
| Radio standard GSM | | No |
| Radio standard UMTS | | No |

| | | | |
|--|--|----|-------|
| IO link master | | | No |
| Redundancy | | | No |
| With display | | | No |
| Degree of protection (IP) | | | IP20 |
| Basic device | | | Yes |
| Expandable | | | Yes |
| Expansion device | | | No |
| With timer | | | Yes |
| Rail mounting possible | | | Yes |
| Wall mounting/direct mounting | | | Yes |
| Front build in possible | | | No |
| Rack-assembly possible | | | No |
| Suitable for safety functions | | | No |
| Category according to EN 954-1 | | | |
| SIL according to IEC 61508 | | | None |
| Performance level acc. to EN ISO 13849-1 | | | None |
| Appendant operation agent (Ex ia) | | | No |
| Appendant operation agent (Ex ib) | | | No |
| Explosion safety category for gas | | | None |
| Explosion safety category for dust | | | None |
| Width | | mm | 107.5 |
| Height | | mm | 90 |
| Depth | | mm | 72 |

Approvals

| | | | |
|-----------------------------|--|--|---|
| Product Standards | | | IEC/EN see Technical Data; UL 508; CSA C22.2 No. 142-M1987; CSA C22.2 No. 213-M1987; CE marking |
| UL File No. | | | E135462 |
| UL Category Control No. | | | NRAQ |
| CSA File No. | | | 012528 |
| CSA Class No. | | | 2252-01 + 2258-02 |
| North America Certification | | | UL listed, CSA certified |
| Degree of Protection | | | IEC: IP20, UL/CSA Type: - |

Dimensions

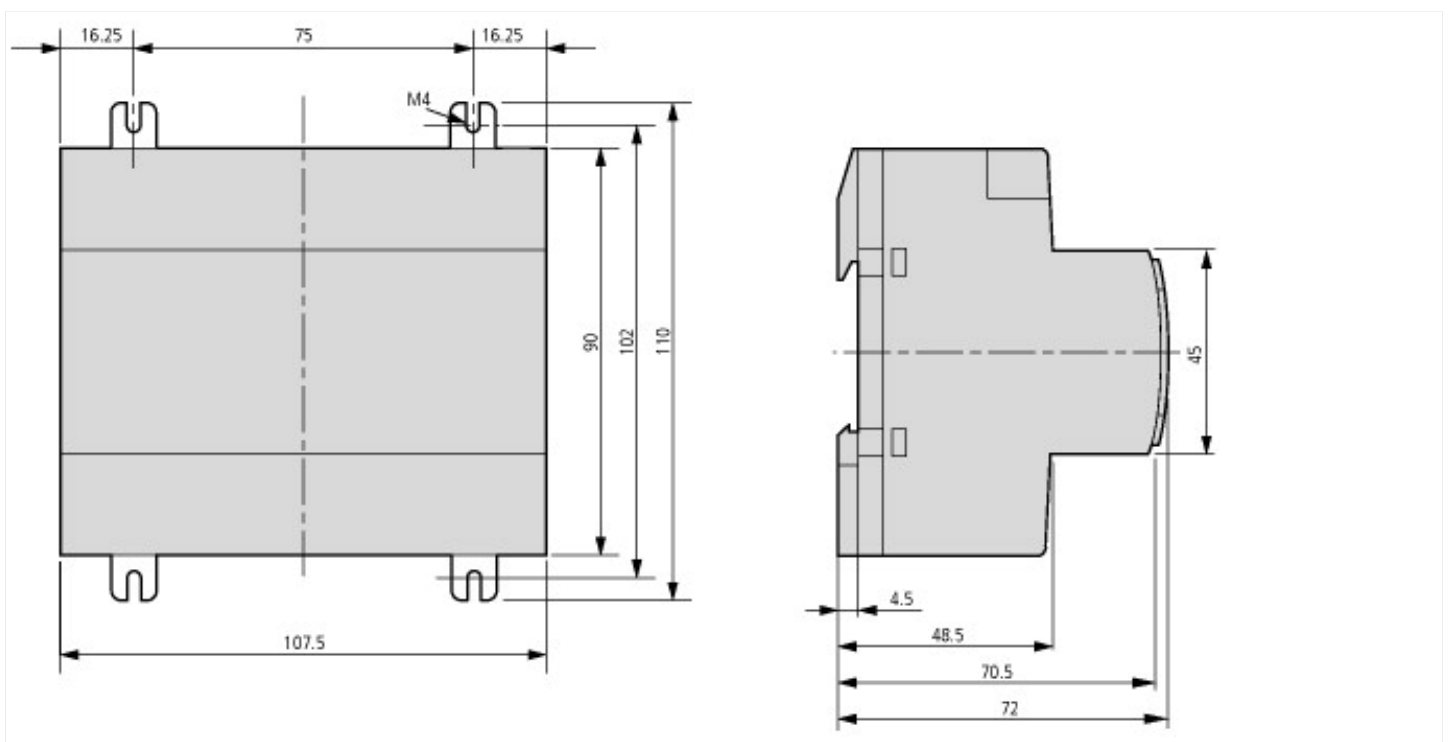

Additional product information (links)

| | |
|---|---|
| Instruction leaflet "easy control relays" IL05013012Z (AWA2528-1979) | |
| Instruction leaflet "easy control relays" IL05013012Z (AWA2528-1979) | ftp://ftp.moeller.net/DOCUMENTATION/AWA_INSTRUCTIONS/IL05013012Z2010_11.pdf |
| Manual "easy800 control relays" MN04902001Z (AWB2528-1423) | |
| MN04902001Z (AWB2528-1423) Steuerrelais easy800 - Deutsch | ftp://ftp.moeller.net/DOCUMENTATION/AWB_MANUALS/MN04902001Z_DE.pdf |
| MN04902001Z (AWB2528-1423) easy800 control relay - English | ftp://ftp.moeller.net/DOCUMENTATION/AWB_MANUALS/MN04902001Z_EN.pdf |
| Labeleditor (Beschriftungssoftware) | http://downloadcenter.moeller.net/de/software.f6023a63-5acb-42c7-a51c-ccf99091cace |