



## OP-EX 4

### Extruder Controller

- 4 digit process value(PV) and 4 digit set value(SV) Display
- Process input (TC)
- Programmable ON/OFF, P, PI, PD and PID control forms
- Adaptation of PID Coefficients to the system with Self-Tune operation (Step Response Tuning)
- Programmable Heating or Cooling Functions for Control Output
- Run output

#### SPECIFICATIONS :

##### Process Input: TC

Termocopl (TC): J (IEC584.1)(ITS90)

Measurement Range : 0 - 500°C

Accuracy: Skalanin ± %0.25'i,

Cold Junction Compensation : Automatically ±0.1°C/1°C

Sensor Break Protection:Upscale

Sampling Cycle :4 samples per second

Input Filter: 1.0 second.

Control Form: ON/OFF, P, PI, PD or PID (Control form can be programmed by the user.)

##### OUTPUT

Heating Output: SSR Driver Output (Maximum 20mA @12V ---)

Cooling Output: Relay (5A@250V~ at resistive load)

Run Output: Relay (5A@250V~ at resistive load)

##### SUPPLY VOLTAGE

230V ~ ( ±15% ) 50/60 Hz - 3VA

115V ~ ( ±15% ) 50/60 Hz - 3VA

24V ~ ( ±15% ) 50/60 Hz - 3VA

(It must be determined in order)

##### DISPLAY

###### Process Display :

10.1 mm Red 4 digits LED Display

###### Set Value Display :

8 mm Green 4 digits LED Display

###### Leds :

SV (Heating Set value), O1 (Heating output Status Led) , O2 (Cooling output status Led), O3 (Run output Status Led), °C , °F Leds

##### ENVIRONMENTAL RATINGS and PHYSICAL SPECIFICATIONS

Operating Temperature: 0..50°C

Humidity : 0-90%RH (none condensing)

Protection Class : IP65 at front, IP20 at rear

Weight: : 220 gr.

Dimension : 48 x 48mm, Depth:95 mm

Panel CutOut : 46 x 46mm

## ELECTRICAL WIRING

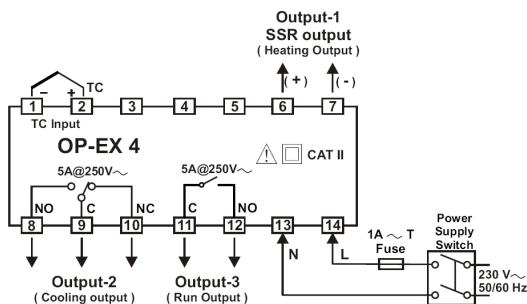

### Changing Heating Set value, Wait Mode Set value and Cooling Set values

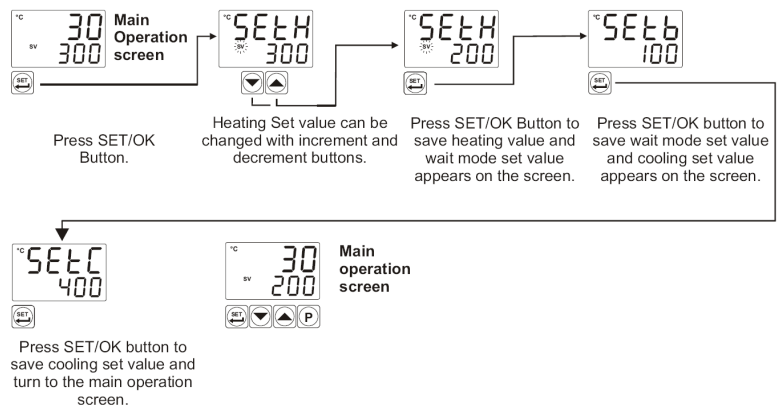

### Turn to the Wait Mode

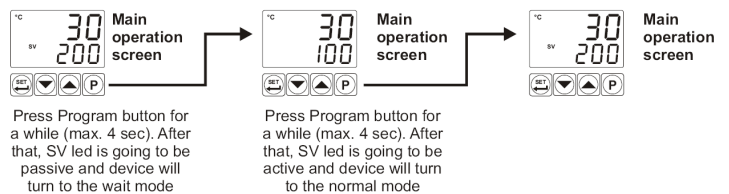

Note-1: To exit changing Set menu without saving the set value, press program button **P**

Note-2: While on the main operation screen, heating set value can be changed with **↓** and **↑** buttons. New set value will be saved after 3 seconds.

Note-3: On the top display "--tC" appears, if the sensor breaks.

Note-4: Cooling Set value SEtC is shown, if CSEt = dEP

## Easy Access Diagram of Technician Parameters

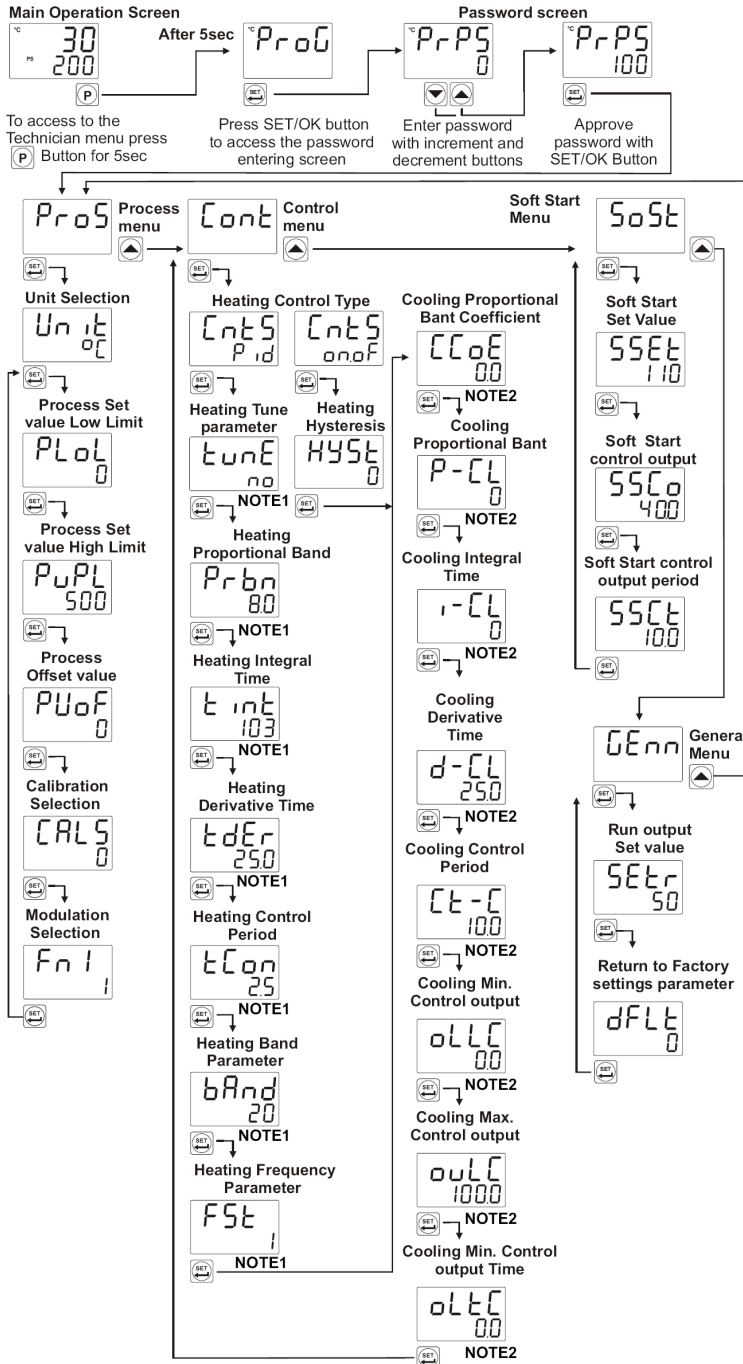

## Technician Parameter Definitions

### ProG : Process Menu Parameters

- Unit** : Unit Selection. It can be adjusted as  $\text{OC}$  or  $\text{OF}$  display type.
- PLoL** : Process Set value Low Limit. It can be adjusted from low limit of input type scale low limit to PuPL value.
- PuPL** : Process Set value High Limit. It can be adjusted from PLoL to high limit of input type scale high limit.
- PUoF** : Display offset for process value. It can be adjusted -10% to +10% of scale. The defined value is added to process value.
- CAL5** : Device input(sensor) read type. It can be adjusted from 0(factory) to 1(user).
- FnI** : Device Output modulation type selection parameter. It can be adjusted from 0 (no modulation) to 1 (modulation).

### Cont : Control Menu Parameters

- CntS** : Heating Control Type Selection. It can be adjusted from  $\text{onOF}$  to  $\text{Pid}$
- tunE** : If Tune parameter is adjusted to  $\text{YES}$ , then device starts to calculate PID parameters automatically. This parameter is shown when  $\text{CntS} = \text{Pid}$
- Prbn** : Heating Proportional Band. It can be adjusted from %1 to %100.
- tInt** : Heating Integral Time. It can be adjusted from 0 to 3600 second.
- tDEr** : Heating Derivative Time. It can be adjusted from 0.0 to 999.9 second.
- tCon** : Heating output Control Period. It can be adjusted from 0.1 to 150.0 second.
- HYSL** : Hysteresis parameter. It can be adjusted from %0 to %50 of defined scale( $\text{PuPL} - \text{PLoL}$ )
- bAnd** : Band parameter. After Soft Start operation, this parameter determine that how much degree is remaining to set value for the continuous power operation.
- FSE** : If the device output is modulated, this parameter determine it's modulation frequency. If the parameter value is decreasing, modulation frequency is increasing. If the parameter value is increasing, modulation frequency is decreasing.
- CCoE** : Cooling Proportional Band Coefficient. Cooling proportional parameter  $\text{P-CL}$  is calculated with heating proportional band value  $\text{Prbn}$  and coefficient  $\text{CCoE}$
- P-CL** : Cooling Proportional Band. It can be adjusted from %1 to %100.
- i-CL** : Cooling Integral Time. It can be adjusted from 0 to 3600 second.
- d-CL** : Cooling Derivative Time. It can be adjusted from 0.0 to 999.9 second.
- CL-C** : Cooling output Control Period. It can be adjusted from 0.1 to 150.0 second.
- oLLC** : Cooling Minimum Control output. It can be adjusted from %0.0 to  $\text{oULC}$
- oULC** : Cooling Maximum Control output. It can be adjusted from  $\text{oLLC}$  to %100.0.
- oLLE** : Cooling Minimum Control output time. It can be adjusted from 0.0 second to  $\text{CL-C}$

### SoSt : Soft Start Menu Parameters

- 5SEt** : Soft Start operation is working until process value reach this parameter value.
- 55Co** : Soft Start operation control output percent.
- 55CLt** : Soft Start operation output period.

### GEnn : General Menu Parameters

- 5Etr** : Run output set value. While the process value is higher than this parameter value, run output is active.
- dFLt** : Return to factory settings. It can be adjusted from 0 to 1. After the user adjust the parameter to 1 and save it, on the new power on the device, the factory settings is downloaded the device.

**Note-1:** In the Program menu, the parameters can be changed with increment and decrement buttons.

**Note-2:** To exit without saving the parameter value, press **P** button a basiniz. Thus, you can return on the top of the menu list.

**Note-3:** In the Program menu, if you do not press any button for 20 seconds, the device exit from program menu and return to the main operation screen.

## Tune Operation

### To start Tune operation:

- 1- Enter the Program menu.
  - 2- In the **Cont** menu, adjust **tunE** parameter to **YES** and press SET/OK button to approve the parameter and return the main operation screen
  - 3- Observe "tunE" blinks in Set display.
- Note-** For starting the Tune operation,  
**Heating Tune Operation:** Process value must be lower than process set value at least 5% of full scale  
**Cooling Tune Operation:** Process value must be greater than process set value at least 5% of the full scale. If this condition is not okay, **tErr** blinks on the screen for 10 seconds.

### To cancel Tune operation :

- 1- If sensor breaks ;
- 2- If **Self Tune** operation can not be completed in 8 hours ;
- 3- While heating **Self Tune** is running, if process value becomes greater than Process Set value
- 4- While **Self Tune** operation is running, if user changes the process set value; Then **Self Tune** operation is canceled, device continues to run with former PID parameters without changing PID parameters.

## Order Information

OP-EX 4 (48x48 DIN 1/16)												
A	BC	D	E	/	FG	HI	/	U	V	W	Z	
	23	0	2	/	01	01	/	0	0	0	0	

<b>A</b>	<b>Power Supply</b>
3	24V ~ ( ± %15 ) 50/60Hz
4	115V ~ ( ± %15 ) 50/60Hz
5	230V ~ ( ± %15 ) 50/60Hz
<b>BC</b>	<b>Input Type</b>
23	J, Fe CuNi IEC584.1(ITS90)
	<b>Scale</b>
	-200°C, 900°C -328°F, 1652°F
<b>D</b>	<b>Communication</b>
0	Yok
<b>E</b>	<b>Heating Output</b>
2	SSR Driver output Max. 20mA @12V
<b>FG</b>	<b>Cooling Output</b>
01	Relay Output (5A@250V~ on Resistive Load)
<b>HI</b>	<b>Run Output</b>
01	Relay Output (5A@250V~ on Resistive Load)

## Easy Access Diagram of Operator Parameters

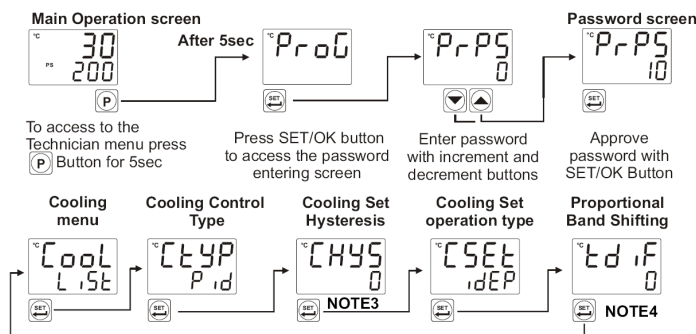

- NOTE1:** If Heating Control Type **CntS** is selected as ON.OF, then these parameters are not shown.
- NOTE2:** If Cooling Control Type **CLYP** is selected as ON.OF, then these parameters are not shown.
- NOTE3:** If Cooling Control Type **CLYP** is selected as PID, then this parameter is not shown.
- NOTE4:** If Cooling Set Operation Type **CSEt** is selected as dEP, then this parameter is not shown.

## Operator Parameters Definitions

- CLYP** : Cooling operation type selection parameter. It can be adjusted as ON/OFF or PID.
- CHYS** : Cooling Set Hysteresis value. It is active when Cooling type is selected as ON/OFF.
- CSEt** : Cooling Set operation. If it is selected as dEP, cooling set value = SetH+tdIF. If it is selected as ldep, cooling set value = SetC.
- tdIF** : Cooling Proportional Band Shifting. If **CSEt** parameter is dEP, it is shown.